



<http://support.kesseboehmer.de/etouch>

Montageanleitung

Hochschrankauszug

Mounting Instructions

Larder Pull-out

Notice de montage

Coulisse

DISPENSA
VVS-x

Convoy Premio

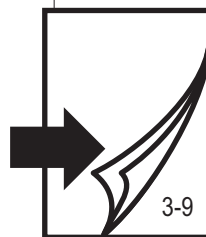
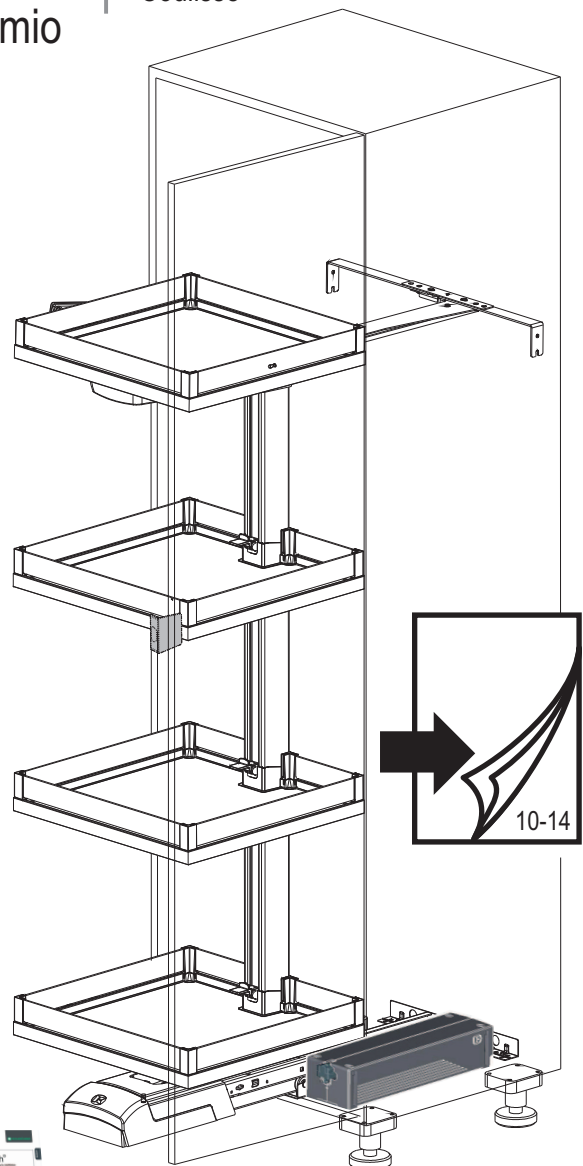
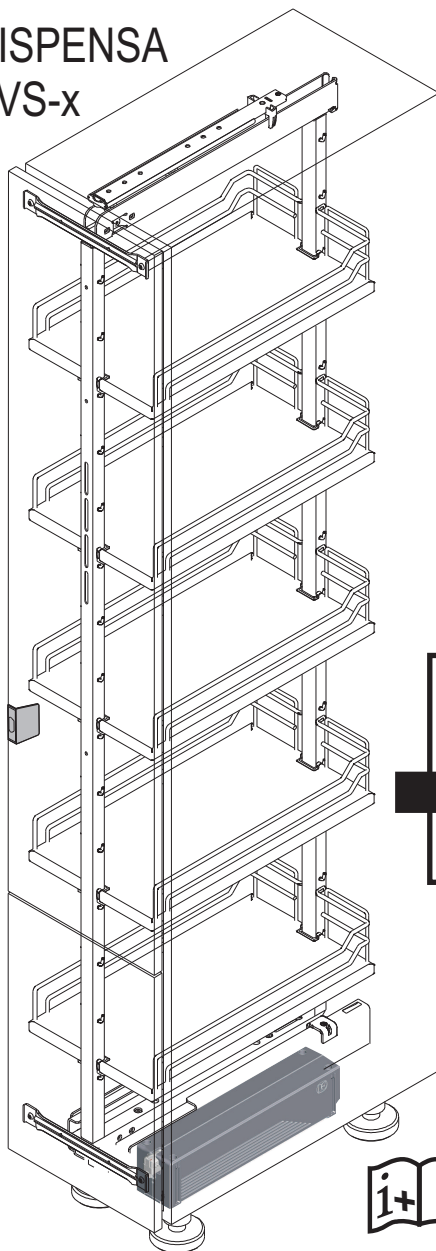

1X

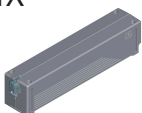

1X

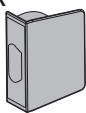

1X

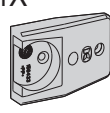

1X



1X



4X

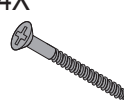

1X

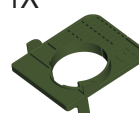

1X

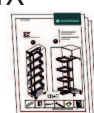

1X



SYMBOLE ▪ SYMBOLS ▪ SYMBOLES ▪ SIMBOLI ▪ SÍMBOLOS ▪ SÍMBOLOS ▪ MERKIT ▪ SYMBOLER ▪ SYMBOLY ▪ SYMBOLE ▪ 記号 ▪ 标志

Warnung! ▪ Warning! ▪ Avertissement! ▪ Avvertenza! ▪ ¡Advertencia! ▪ Aviso! ▪ Varoitus! ▪ Advarsel! ▪ Výstraha! ▪ Ostrzeżenie!
警告 ▪ 警告!



Nicht korrekt! ▪ Incorrect! ▪ Incorrect! ▪ Non corretto! ▪ ¡Incorrecto! ▪ Incorrecto! ▪ Väärin! ▪ Ikke korrekt! ▪ Nesprávně! ▪
Nieprawidłowo! ▪ 正しくありません ▪ 不正确!



Korrekt! ▪ Correct! ▪ Correct! ▪ corretto! ▪ ¡Correcto! ▪ Correcto! ▪ Oikein! ▪ Korrekt! ▪ Správně! ▪ Prawidłowo! ▪ 正しいです ▪ 正确!



Fixieren/fixiert! ▪ Secure/Secured! ▪ Fixer/fixé ▪ Fissare/fissato! ▪ ¡Fijar/fijado! ▪ Fixar/fixo! ▪ Kiinnitä/kiinnitetty! ▪ Spænde/spændt ▪
Upevnit/upevněno! ▪ Zamocować/zamocowane! ▪ 固定する ▪ 已锁紧!



Lösen/gelöst! ▪ Release/Released! ▪ Détacher/détaché ▪ Allentare/allentato! ▪ ¡Soltar/suelto! ▪ Soltar/solto! ▪ Irroita/irroitettu! ▪
Løsne/løsnet ▪ Povolit/povoleno! ▪ Zwolnić/zwolnione! ▪ はずす ▪ 松开/已松开!



PZ-2 Schraubendreher verwenden! ▪ Use a PZ-2 screwdriver! ▪ Utiliser un tournevis PZ-2 ▪ Usare il cacciavite Pz-2! ▪ ¡Utilizar un
destornillador PZ-2! ▪ Usar chave de parafusos PZ-2! ▪ Käytä PZ-2 ruuvitalttaa! ▪ Brug PZ-2 skruetrækker! ▪ Použite krížový
šroubovák PZ-2! ▪ Użyc wkrętaka PZ-2! ▪ 手動のスクリュードライバー使用してください。 ▪ 请使用PZ2螺丝扳手!



Klick-Geräusch beim Einrasten! ▪ Audible click on engagement! ▪ « Clic » lors de l'encliquetage ▪ Quando si innesta si sente un
clic! ▪ ¡Cuando encaja se oye un clic! ▪ Ruído de clique ao engatar! ▪ Lukittuessa kuuluu klik-ääni! ▪ Kliklyd ved montering! ▪
Slyšitelné zacvaknutí! ▪ Trzask przy zaskakiwaniu! ▪ はめるときにカチツという音を確認してください。 ▪ 嵌入时有咔嚓声!



Warnung vor Spannung ▪ Electrical voltage warning ▪ Varování před napětím ▪ Advarsel mod spænding ▪ Advertencia de voltaje
Avertissement indiquant une tension électrique ▪ Varo - vaarallinen jännite ▪ Προειδοποίηση για ηλεκτρική τάση ▪ Avviso presenza ▪
Aviso de tensão ▪ Внимание! Высокое напряжение ▪ Elektrik tehlikesi ▪ 電圧に関する警告 ▪ 电压警告



Netzstecker rein ▪ Connect mains plug ▪ Vysunout síťovou zástrčku ▪ Netstik ud ▪ Desconectar enchufe ▪ Débrancher la prise ▪
Irroita verkkopistoke ▪ Βύσμα έξω ▪ Togliere la spina di rete ▪ Tirar a ficha de rede ▪ Извлечь вилку ▪ Elektrik fişini tak
電源プラグを外す ▪ 断开电源插头



Netzstecker raus ▪ Disconnect mains plug ▪ Zásunout síťovou zástrčku ▪ Netstik ind ▪ Conectar enchufe ▪ Brancher la prise ▪
Kytke verkkopistoke ▪ Βύσμα μέσα ▪ Inserire la spina di rete ▪ Inserir a ficha de rede ▪ Вставить вилку ▪ Elektrik fişini çıkart
電源プラグを挿入する ▪ 接通电源插头



Alle Maße in mm! ▪ All dimensions in mm! ▪ Toutes les dimensions en mm! ▪ Tutte le dimensioni in mm!
▪ ¡Todas las medidas son en mm! ▪ Todas as medidas em mm! ▪ Kaikki mitat mm! ▪ Alle mål er mm! ▪ Všetchny rozměry v mm! ▪
Wszystkie wymiary w mm! ▪ すべての単位は ミリメートルです。 ▪ 所有尺寸单位均为毫米!

Ausziehsicherung vorhanden! ▪ Pull-out stop available! ▪ Présence d'une protection anti-sortie! ▪ Sicura di estrazione presente! ▪
¡Tope de seguridad integrado! ▪ Protecção contra extracção disponível! ▪ Varusteena ulosvetopysäytin ▪ Med udtræksstop! ▪
Nainstalovaná pojistka proti vytažení! ▪ Zamontowano zabezpieczenie przed wyciągnięciem! ▪ 引き出し保護があります。
配备安全锁扣!

Korrosionsprüfung nach DIN EN ISO 6270-2 ▪ Corrosion test according to DIN EN ISO 6270-2 ▪ Contrôle de la corrosion selon
DIN EN ISO 6270-2 ▪ Prova di corrosione secondo la norma DIN EN ISO 6270-2 ▪ Prueba de corrosión según DIN EN ISO 6270-2
▪ Ensaio de corrosão conforme DIN EN ISO 6270-2 ▪ DIN EN ISO 6270-2 muk. korroosiotestaus ▪ Korrosionsprøvning iht. DIN EN
ISO 6270-2 ▪ Korozní zkouška dle DIN EN ISO 6270-2 ▪ Badanie odporności na korozję wg DIN EN ISO 6270-2 ▪
DIN EN ISO 6270-2準拠の腐食検査 ▪ 腐蚀检测符合 DIN EN ISO 6270-2 标准

Die technische Darstellung und Maßangaben – auch bei Abbildungen und Zeichnungen – sind unverbindlich. Konstruktionsverbesserungen sind vorbehalten! ▪ Technical
information and stated dimensions (including in illustrations and drawings) must not be regarded as binding. Design subject to change without notice (in interest of
improvement)! ▪ Les illustrations techniques et les cotes – y compris sur les schémas et les dessins – sont non contractuelles. Sous réserve d'améliorations de la construction!
Le rappresentazioni tecniche e le indicazioni delle dimensioni – anche nelle figure e nei disegni – non sono vincolanti. Con riserva di miglioramenti di progettazione! ▪
Las descripciones técnicas y los datos dimensionales, inclusive los incluidos en fotos y figuras, son meramente orientativos y no vinculantes. ¡Reservado el derecho a mejoras
constructivas! ▪ As descrições técnicas e as indicações de medidas – também em ilustrações e desenhos – não são de natureza imperativa. Salvo melhoramentos de
construção! ▪ Tekniset piirrokset ja mitat – myös kuvissa ja piirroksissa olevat – ovat sitoumuksetta. Oikeus tekniisiin parannuksiin pidätetään! ▪ De tekniske fremstillinger og
måleangivelser – også i figurer og tegninger – er vejledende. Forbehold for konstruktionsforbedringer! ▪ Technické znázornění a rozměry – i na obrázcích a výkresech –
jsou nezávazné. Konstrukční změny vyhrazeny! ▪ Prezentacje techniczne i dane wymiarowe – także na rysunkach – są niewiążące. Zmiany konstrukcyjne zastrzeżone!
技術データおよび寸法は、改良などによって変更されることがあります。
技术图纸和数据 (即使在插图和图纸中) 均不具备法律效力。公司保留进行设计更改的权利!

1

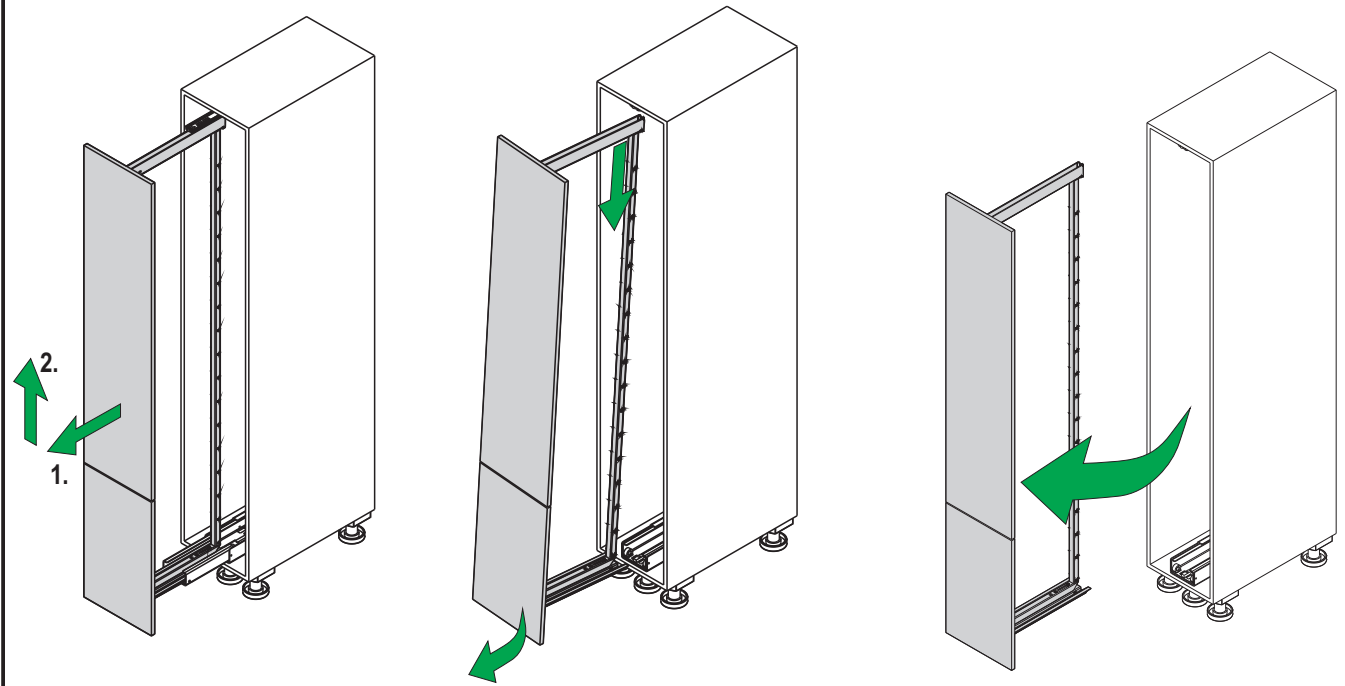

2

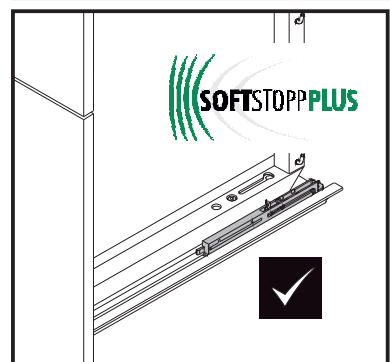
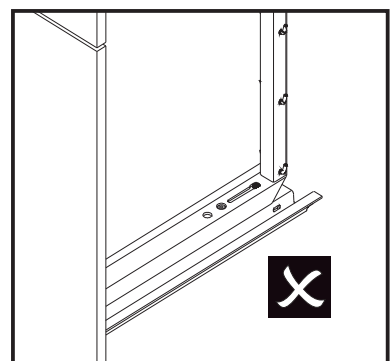
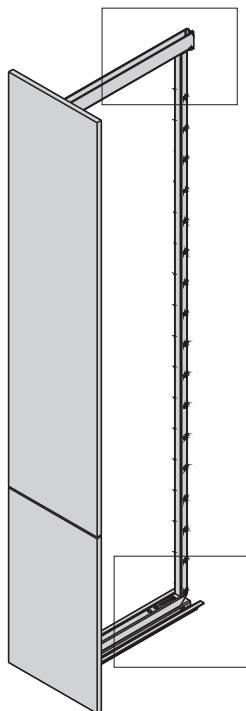
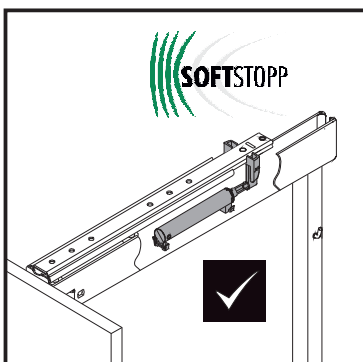
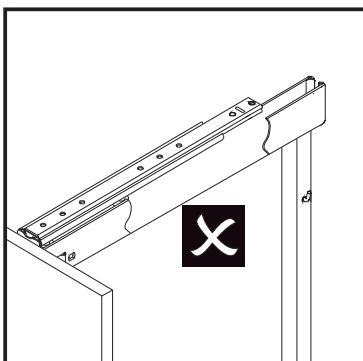

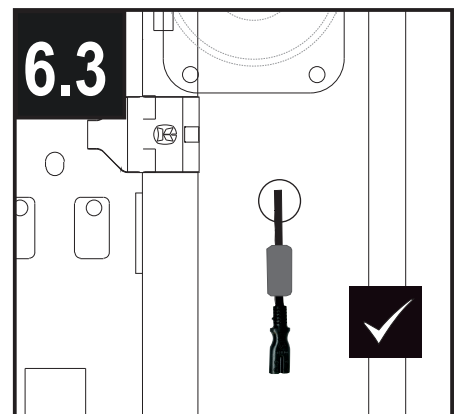
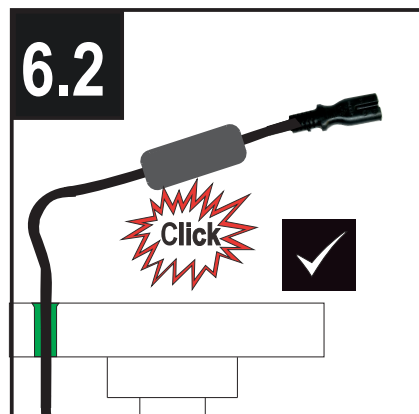
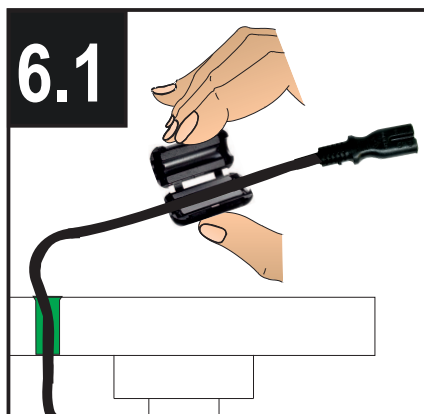
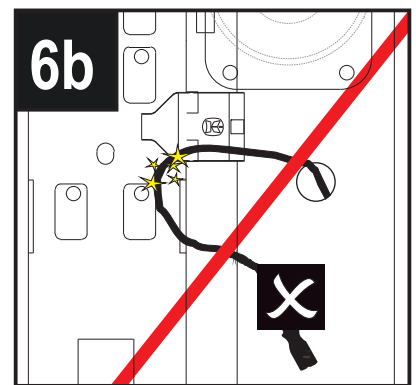
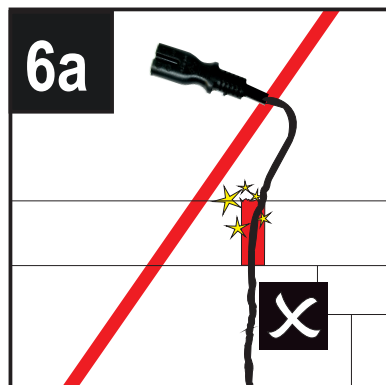
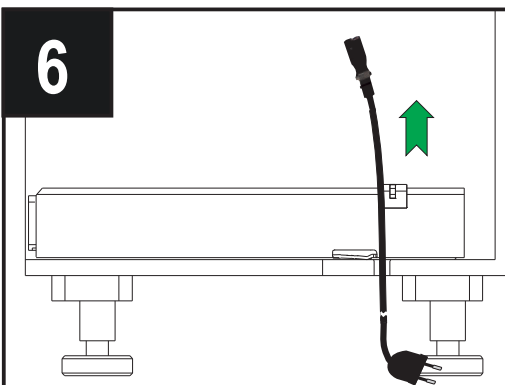
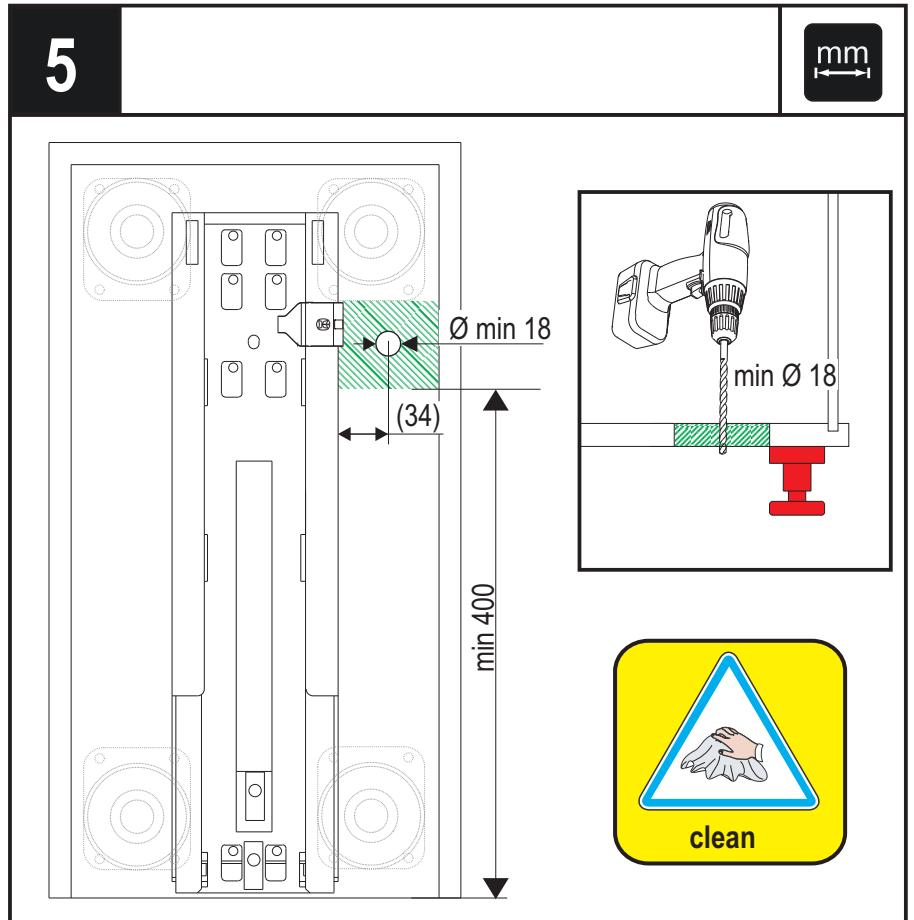
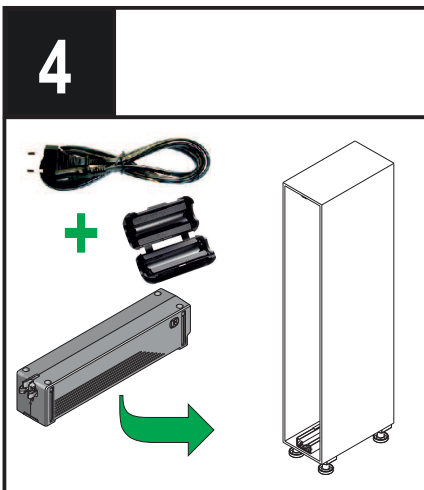
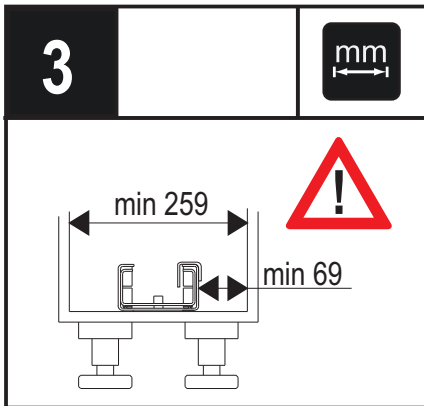

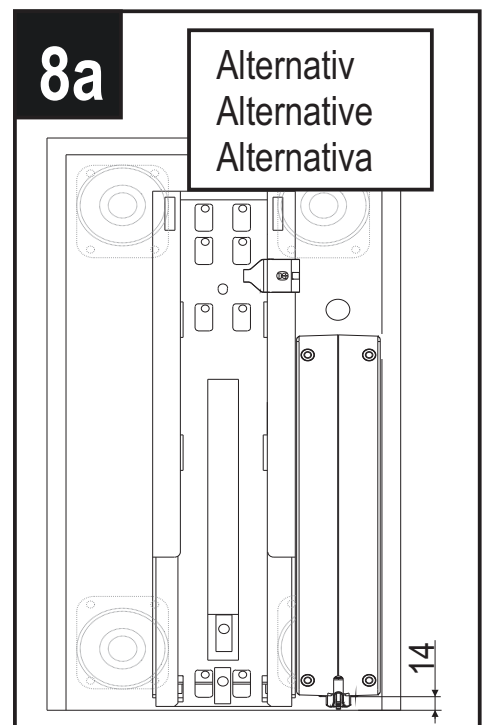
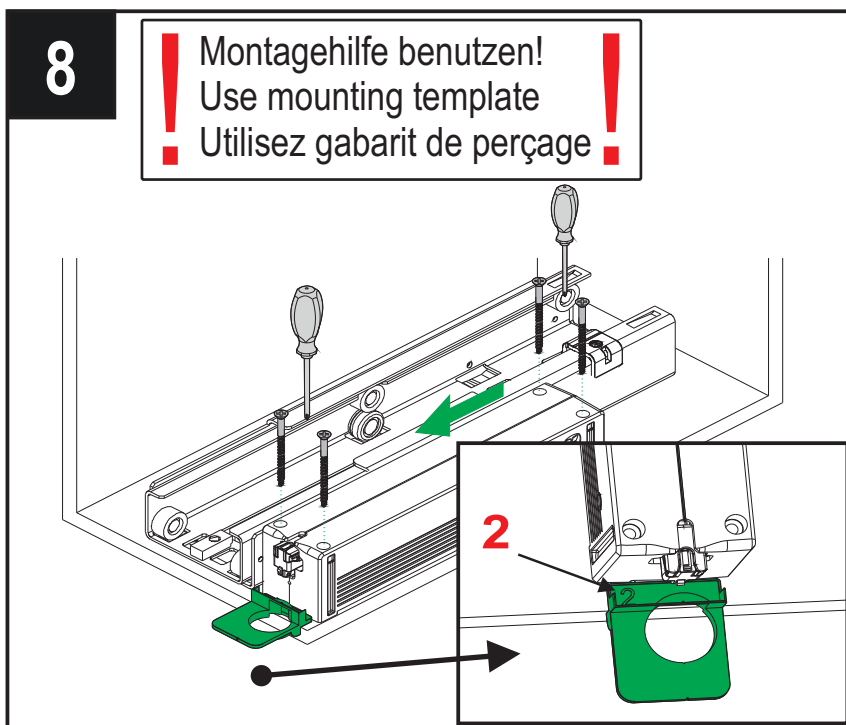
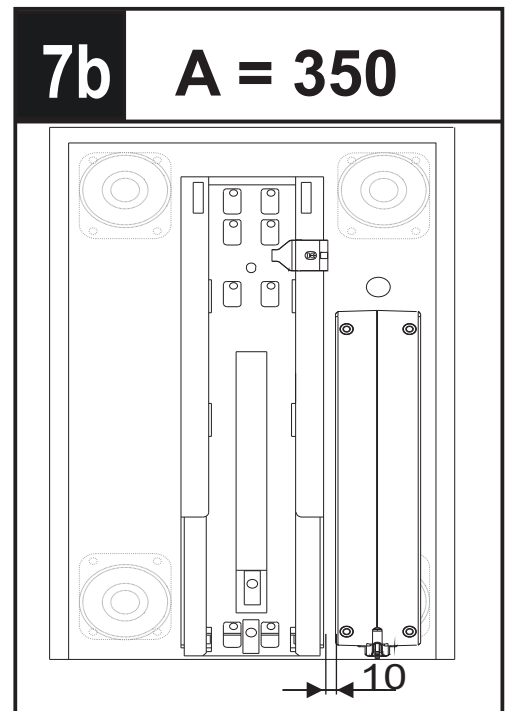
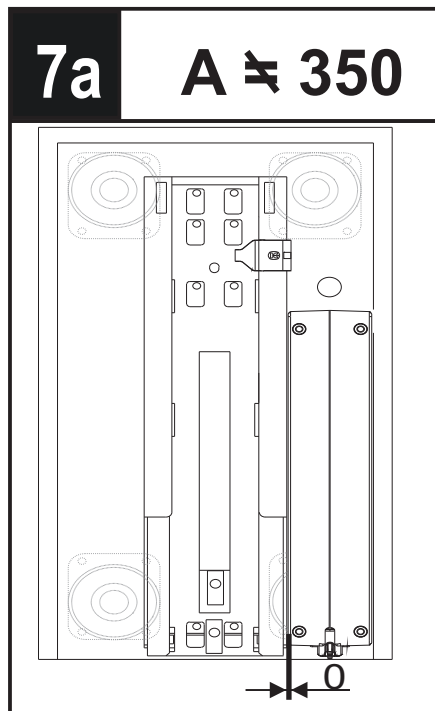
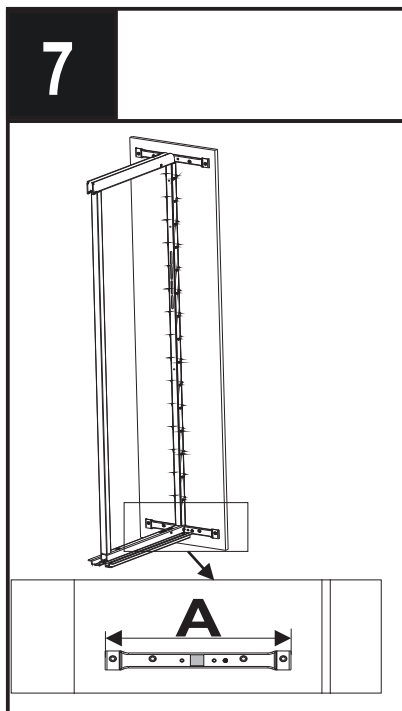
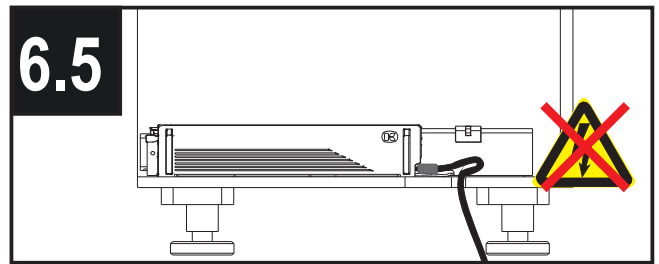
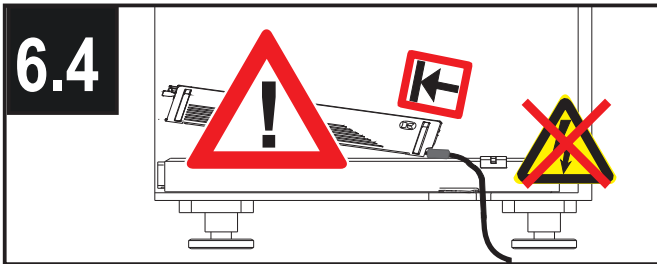

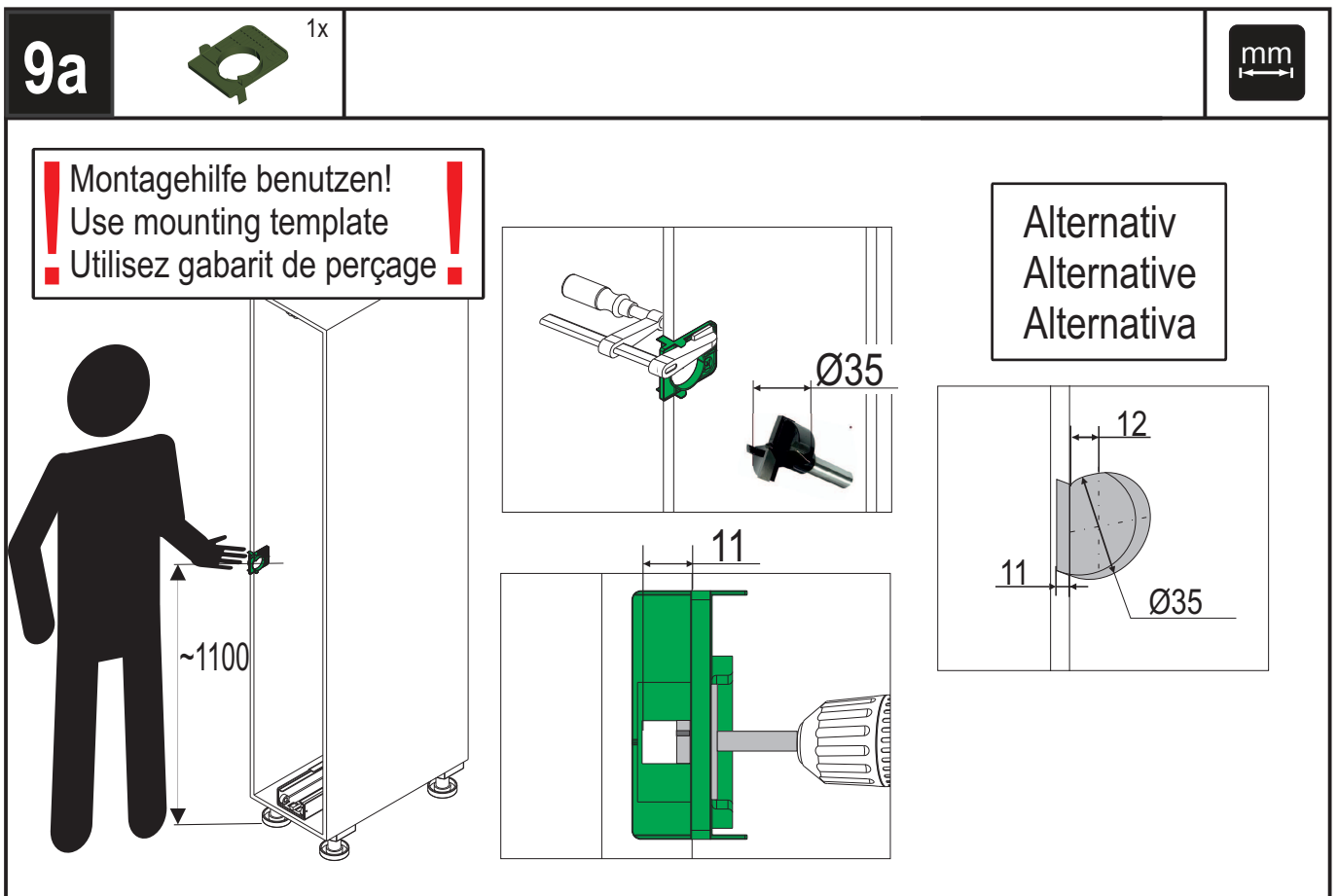
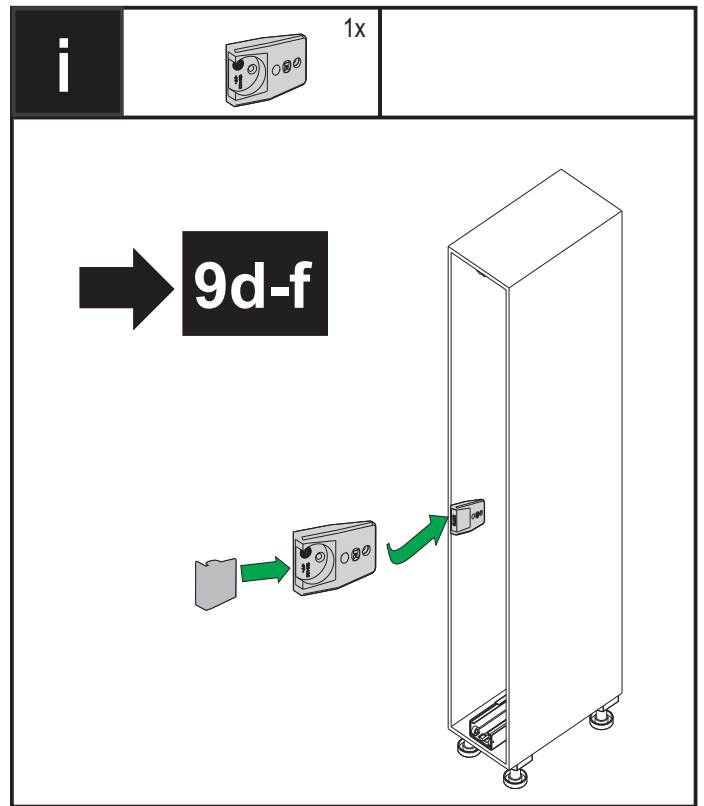
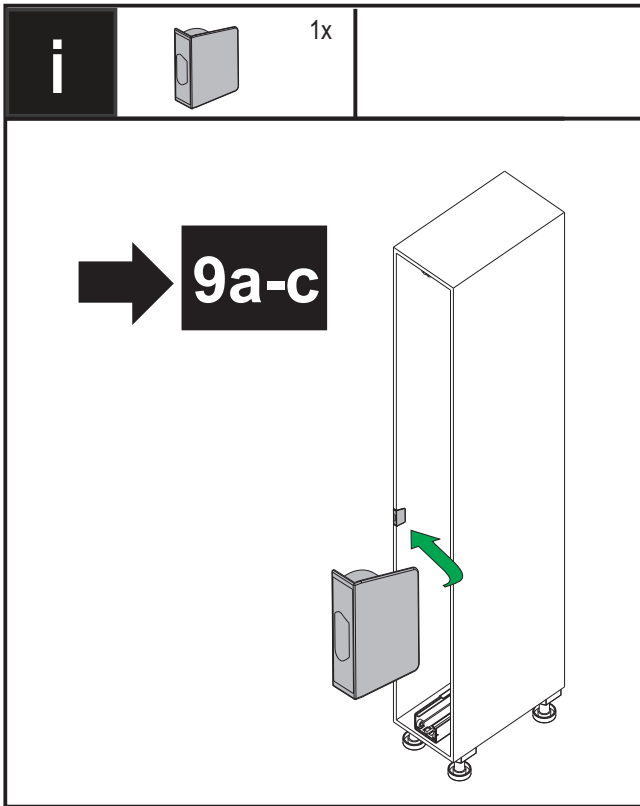

9b



1x

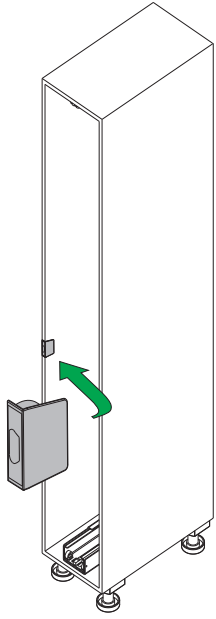
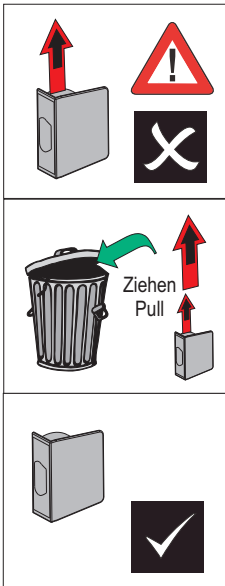

i

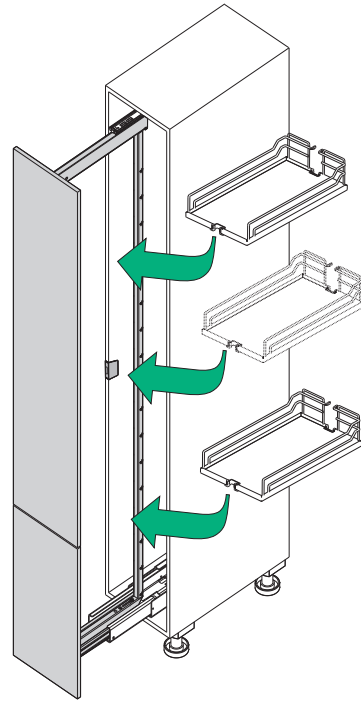

9c

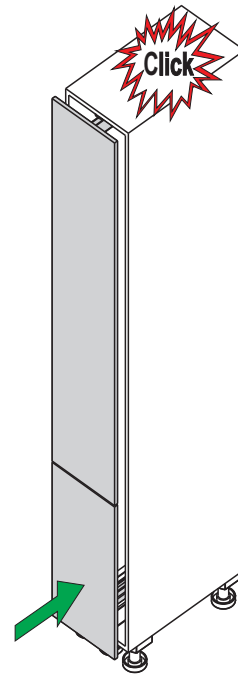
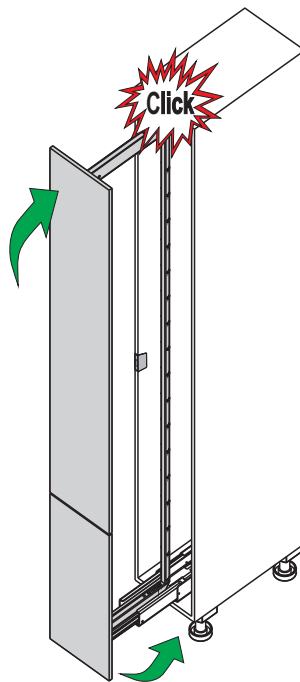
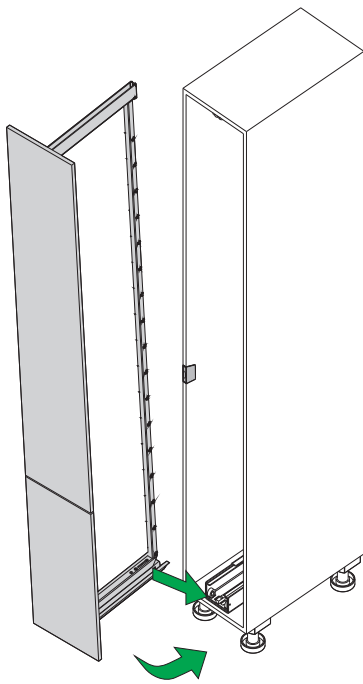

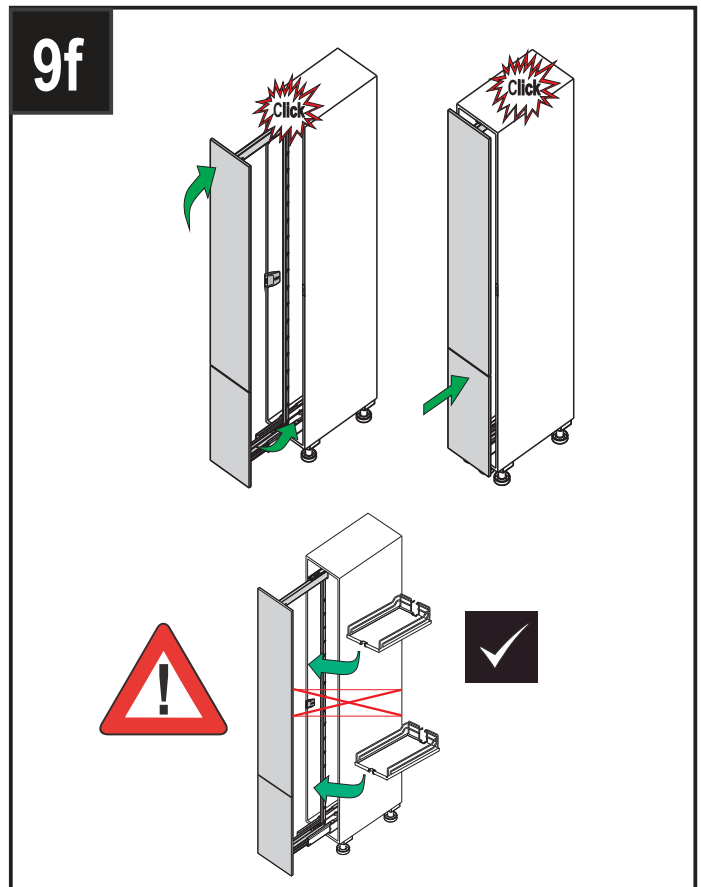
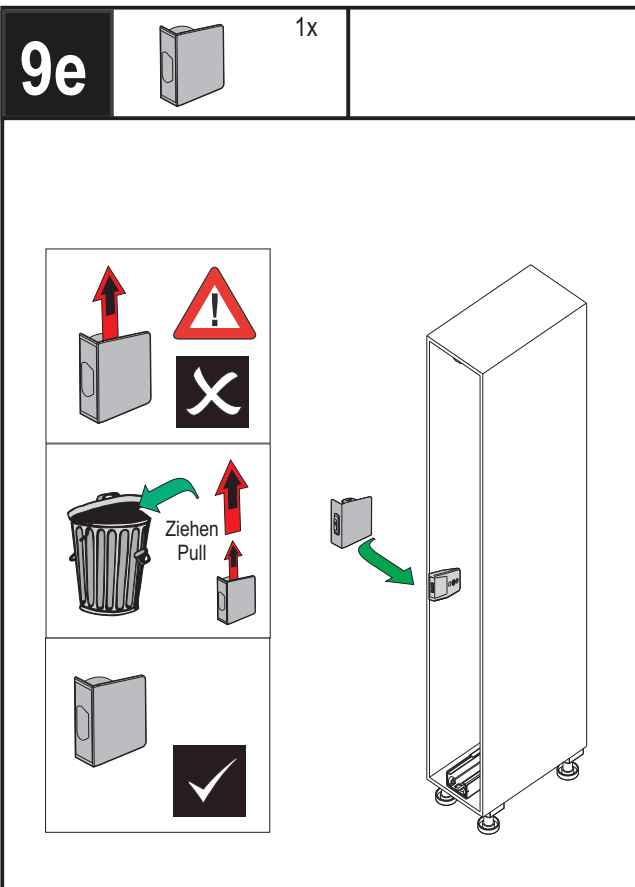
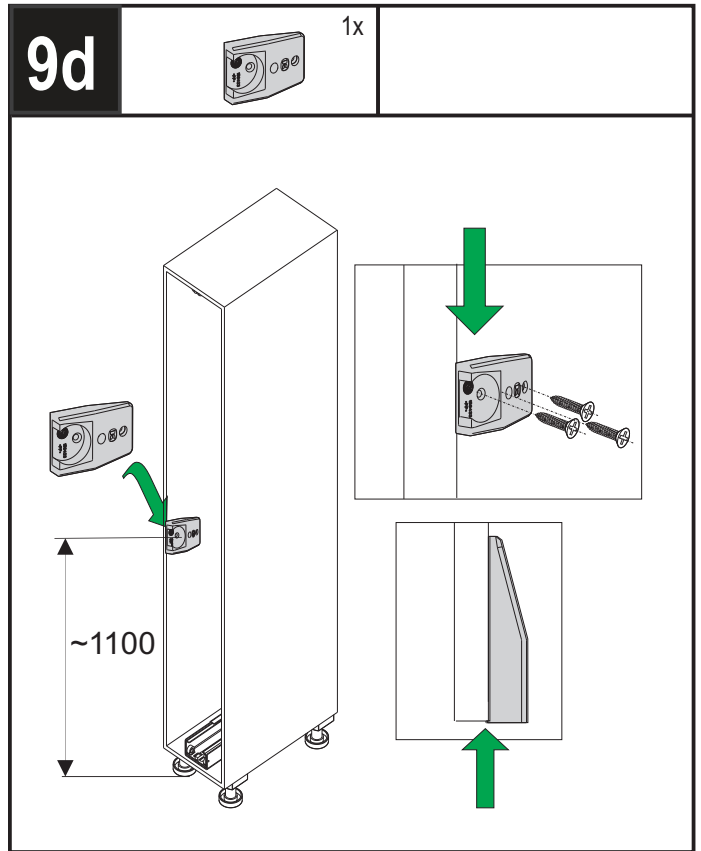
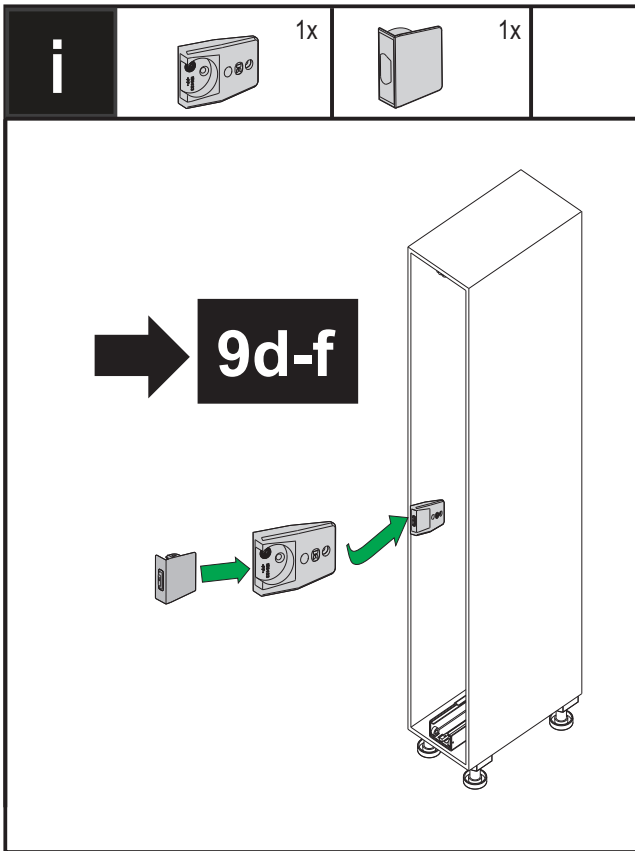

i

DISPENSA
VVS-x

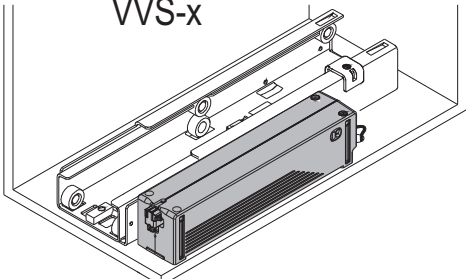



110V AC - 240V AC
60Hz -50Hz
2A

10

Zum Anlernen des Frontsensors, bitte innerhalb von 5 Sekunden nach Anlegen der Netzspannung den Frontsensor betätigen.

To teach the front panel sensor, you need to operate it by pressing on the front within 5 seconds of applying the supply voltage.

Pro zaučení čelního snímače aktivujte snímač do 5 sek. po připojení síťového napětí

For at indlære frontsensoren skal man aktivere denne senest 5 sekunder efter, at netspændingen er tilsluttet.

El sensor frontal debe accionarse a los 5 segundos de conectar la tensión eléctrica.

Pour procéder à l'apprentissage du capteur frontal, appuyez sur le capteur frontal dans les 5 secondes suivant la mise sous tension.

Eturelvyn anturinn opettamista varten sinun tulee käyttää anturia 5 s kuluessa verkkojännitteen kytkemisestä.

Για να ξεκινήσει η διαδικασία εκμάθησης του πρόσθιου αισθητήρα, ενεργοποιήστε εντός 5 sec από τη σύνδεσή του στο δίκτυο, τον πρόσθιο αισθητήρα

Per l'apprendimento del sensore frontale, attivare lo stesso entro 5 secondi dall'applicazione della tensione di rete.

フロントセンサーをプログラミングするには、電源を接続してから **5** 秒以内にフロントセンサーをアクティブにしてください。

Para a aprendizagem do sensor frontal, por favor accione o sensor frontal dentro de 5 seg. após a aplicação da tensão de rede





W celu przyuczenia czujnika frontowego należy uruchomić go w ciągu 5 sekund po włączeniu zasilania

若要示教前侧传感器，请在接通电源 5 秒内确认前侧传感器

Для обучения переднего датчика задействуйте передний датчик в течение 5 секунд после подачи сетевого напряжения

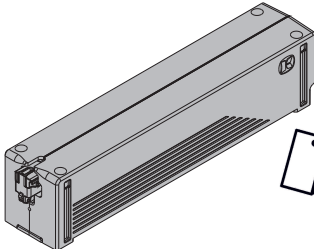
Ön sensörün öğretime fonksiyonunu etkinleştirmek için lütfen ön sensörü elektrik gerilimini oluşturduktan sonra 5 saniye içinde devreye alınız

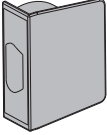
Installation

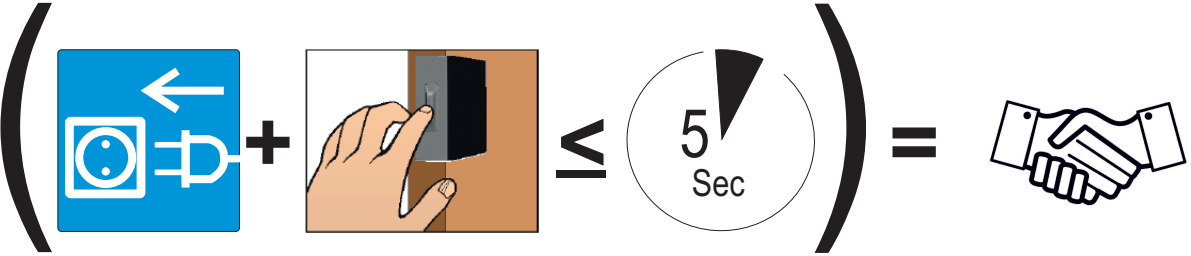

Deinstallation



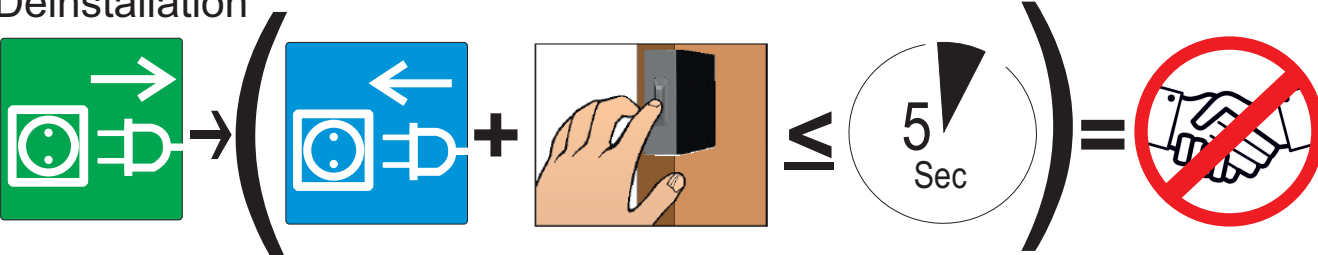

<http://support.kesseboehmer.de/etouch>

Convoy Premio

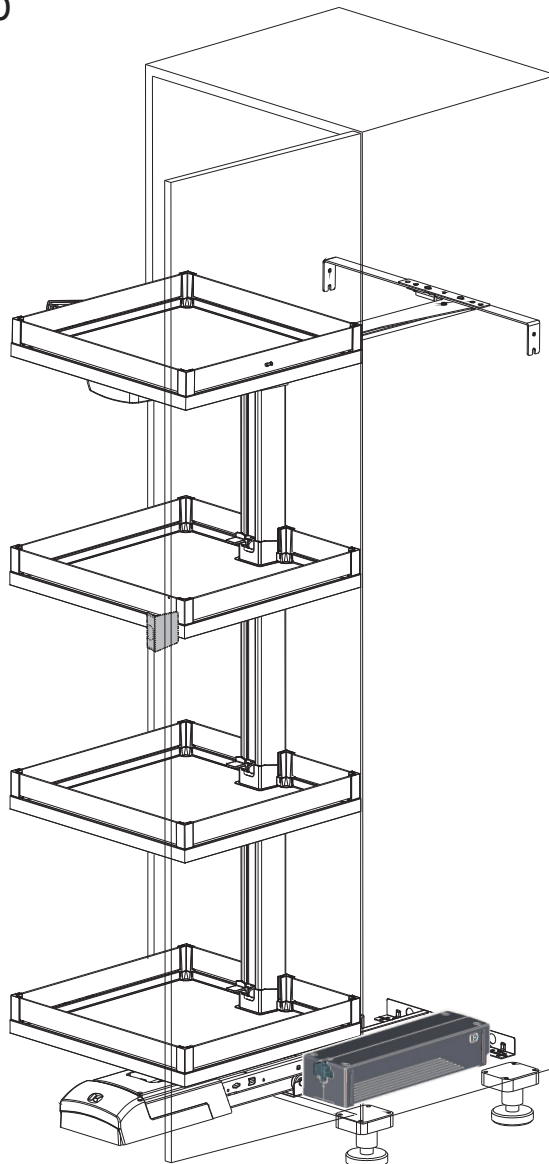

Montageanleitung

Hochschrankauszug

Mounting Instructions

Larder Pull-out

Notice de montage

Coulisse

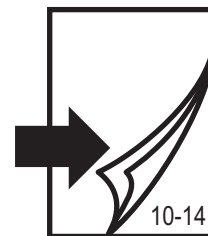

1X

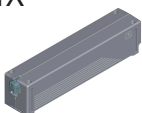

1X

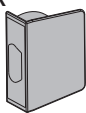

1X

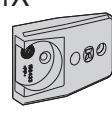

1X



1X



4X

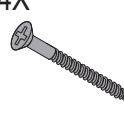

1X

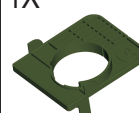

1X

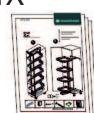

1X



1

! Montagehilfe benutzen
! Use mounting template
! Utilisez gabarit de perçage

Shown for hinge right
 mirrored for left

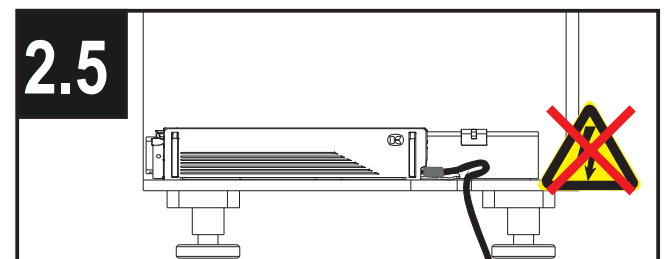
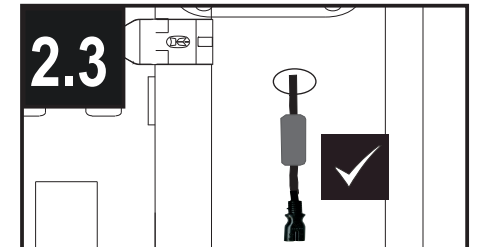
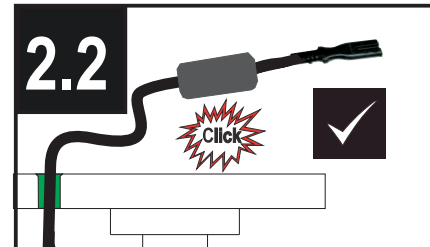
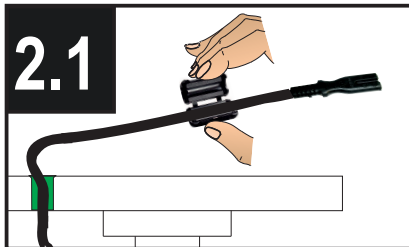
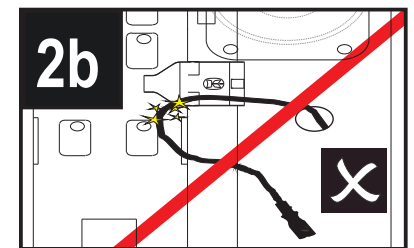
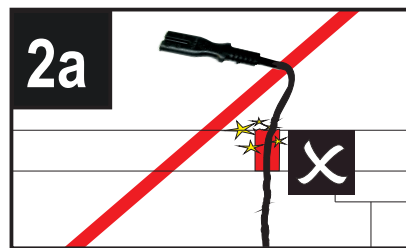
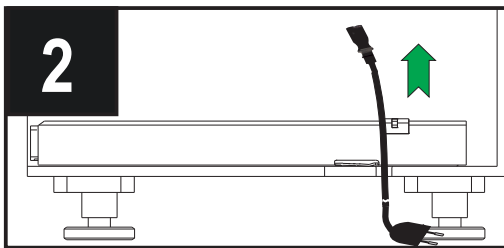
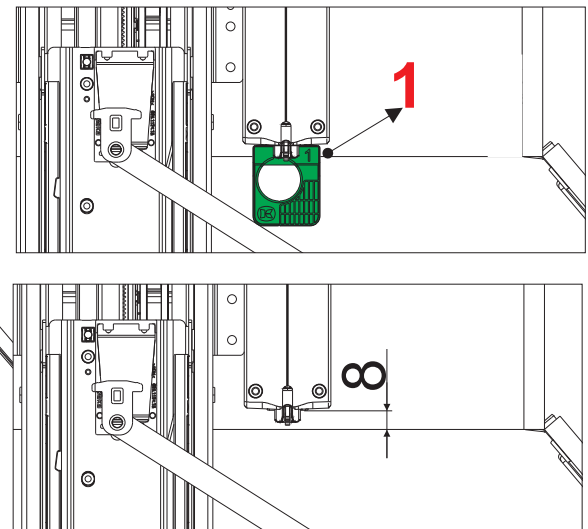
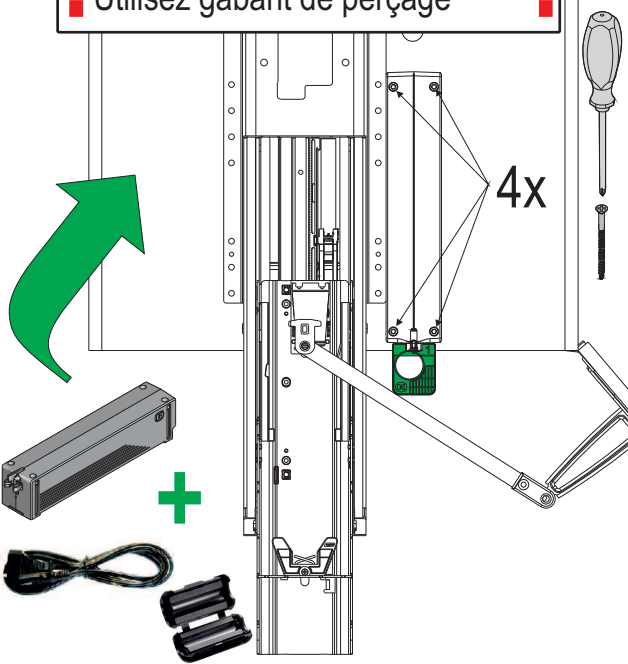
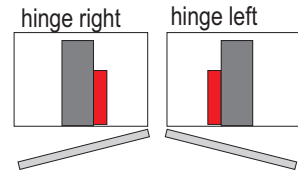

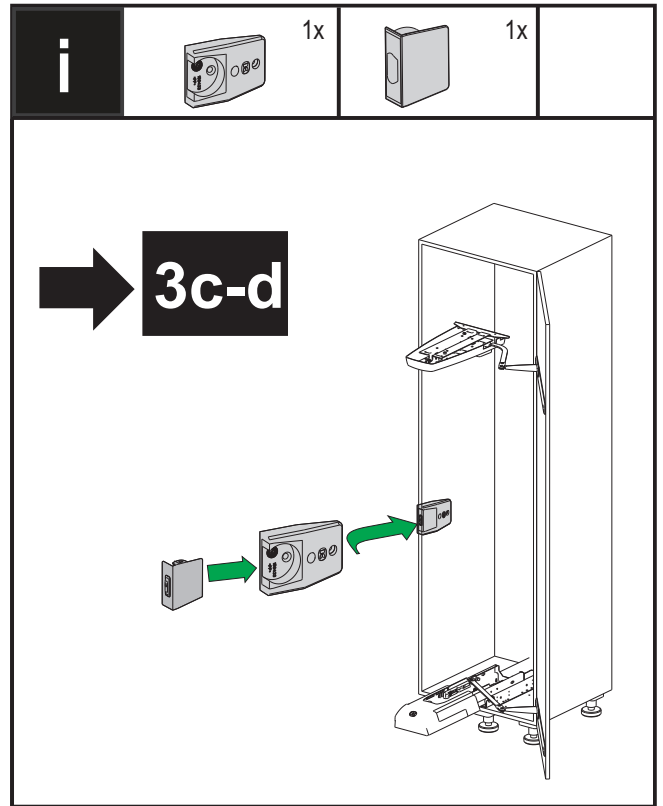
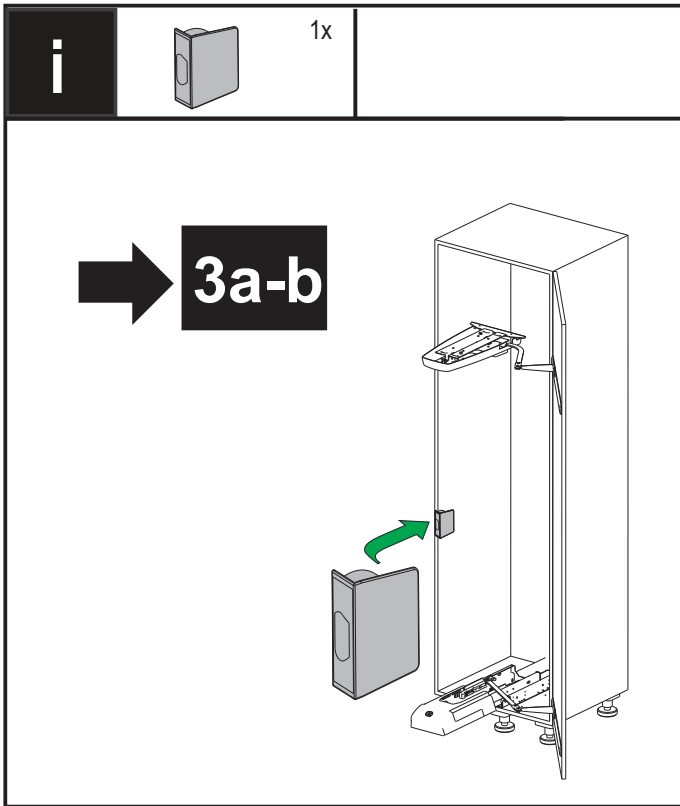

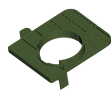
3a		1x	mm ↑↓
-----------	---	----	-----------------

Dargestellt rechts scharniert, links spiegelbildlich
Shown for hinge right, mirrored for left

Achse rechts
hinge right

Achse links
hinge left

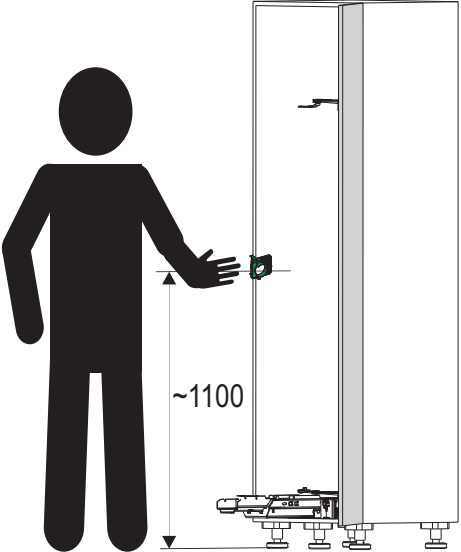

~1100

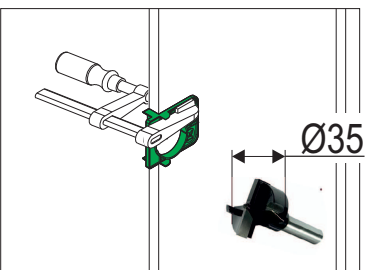

Ø35

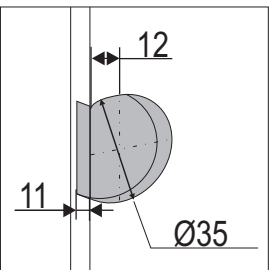

12
11
Ø35

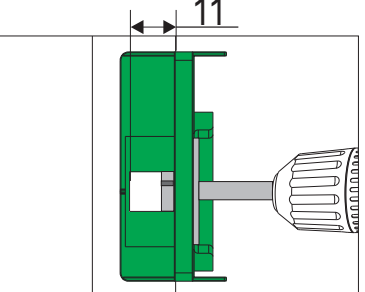



11

! Montagehilfe benutzen !
Use mounting template
! Utilisez gabarit de perçage !

Alternativ
Alternative
Alternativa

3b  1x

3c  1x

3d  1x

i

i

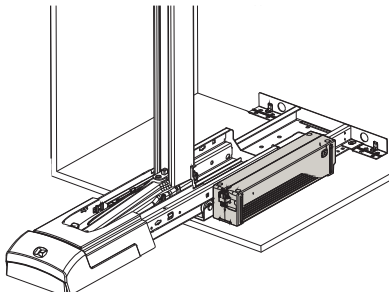



110V AC - 240V AC
60Hz - 50Hz
2A

Convoy Premio

4

Zum Anlernen des Frontsensors, bitte innerhalb von 5 Sekunden nach Anlegen der Netzspannung den Frontsensor betätigen.

To teach the front panel sensor, you need to operate it by pressing on the front within 5 seconds of applying the supply voltage.

Pro zaučení čelního snímače aktivujte snímač do 5 sek. po připojení síťového napětí

For at indlære frontsensoren skal man aktivere denne senest 5 sekunder efter, at netspændingen er tilsluttet.

El sensor frontal debe accionarse a los 5 segundos de conectar la tensión eléctrica.

Pour procéder à l'apprentissage du capteur frontal, appuyez sur le capteur frontal dans les 5 secondes suivant la mise sous tension.

Eturelvyn anturin opettamista varten sinun tulee käyttää anturia 5 s kuluessa verkkojännitteen kytkemisestä.

Για να ξεκινήσει η διαδικασία εκμάθησης του πρόσθιου αισθητήρα, ενεργοποιήστε εντός 5 sec από τη σύνδεσή του στο δίκτυο, τον πρόσθιο αισθητήρα

Per l'apprendimento del sensore frontale, attivare lo stesso entro 5 secondi dall'applicazione della tensione di rete.

フロントセンサーをプログラミングするには、電源を接続してから **5** 秒以内にフロントセンサーをアクティブにしてください。

Para a aprendizagem do sensor frontal, por favor accione o sensor frontal dentro de 5 seg. após a aplicação da tensão de rede





W celu przyczenia czujnika frontowego należy uruchomić go w ciągu 5 sekund po włączeniu zasilania

若要示教前侧传感器，请在接通电源 5 秒内确认前侧传感器

Для обучения переднего датчика задействуйте передний датчик в течение 5 секунд после подачи сетевого напряжения

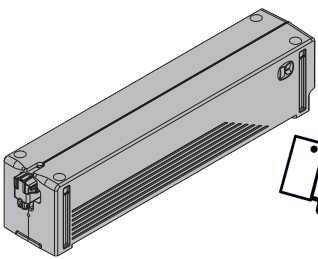
Ön sensörün öğretme fonksiyonunu etkinleştirmek için lütfen ön sensörü elektrik gerilimini oluşturduktan sonra 5 saniye içinde devreye alınız

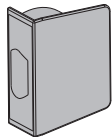
Installation

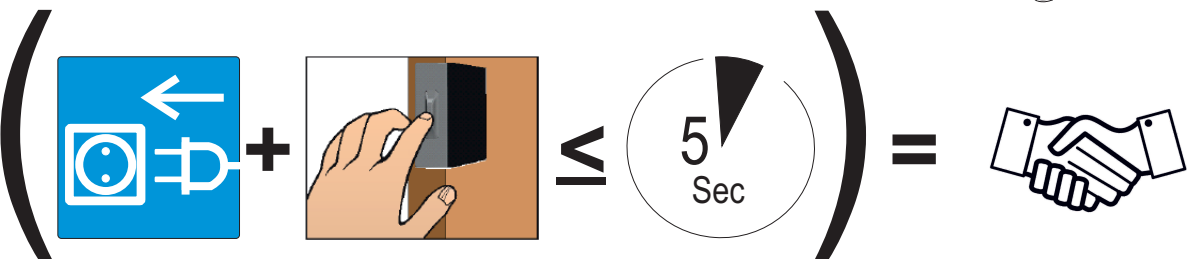

Deinstallation

